

TITAN X

LiFePO4 EMERGENCY CONVERSION KITS



Titan X emergency conversion kits utilise rechargeable LiFePO4 battery technology, to deliver a versatile solution. The compact, low profile design permits installation into shallow ceiling voids, whilst the 230V kit features a flexi-housing construction, to fit through 55mm ceiling cut outs. Each Kit is supplied with necessary connectors, indicators and bezel.

Features

- Versatile kit, fits into shallow ceiling voids
- 230V Kit features flexi-housing to fit small downlight ceiling cutouts
- Uses advanced technology LiFePO4 batteries
- Concise range - makes selection simple
- 230V version ideal for use with Red Arrow non-dimmable GU10 and T8 LED lamps
- Supplied with connectors (where appropriate), indicator, and bezel
- Self Test version ensures compliance with test regime regulations

Specification

Material:	Polycarbonate
Colour Finish:	Black
IP Rating:	IP20
Working Temperature:	5°C to 35°C
Emergency Battery Type:	LiFePO4
Guarantee:	5 Years

Dimensions

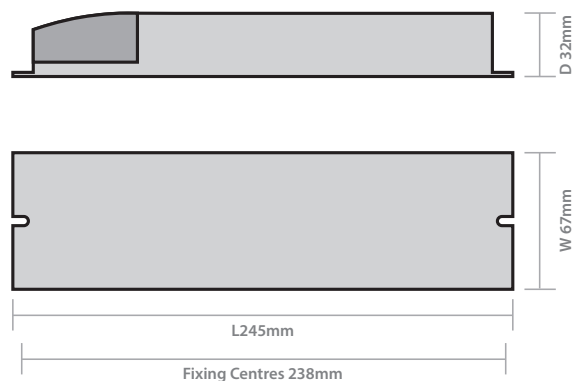

Product Code	Description	Wattage	Battery Voltage	Forward Voltage	Barcodes	Net Weight (kg)
TITANX/4/KIT	Titan X Remote Emergency LiFeP04	4W	6.4V	10-80V	5055807625258	0.4
TITANX/5/KIT/230	Titan X Remote Emergency LiFeP04 230V	5W	6.4V	230V	5055807625265	0.8
TITANX/4/KIT/ST	Titan X Remote Emergency LiFeP04 Self Test	4W	6.4V	10-80V	5055807625272	0.4

A full range of separate Titan X conversion modules and LiFeP04 batteries also available. Contact sales for full details.

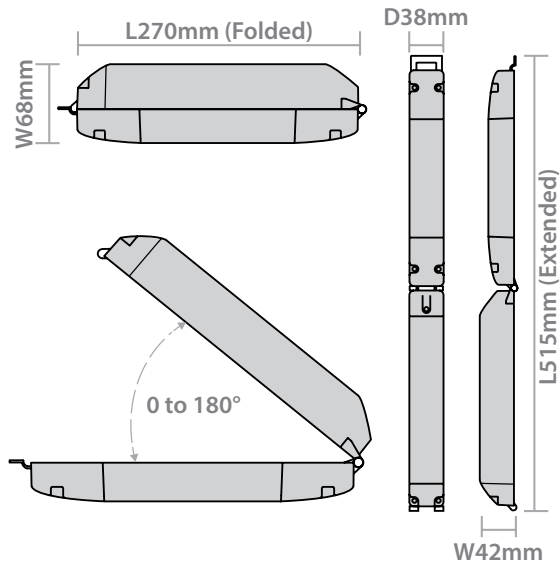

TITAN X/5/KIT/230 Dimensional Diagram



www.redarrowelectrical.co.uk